

NOTE: 1  
 DESIGN CODE:  
 API 17H/6A

NOTE: 2  
 TECHNICAL CLASSIFICATION:  
 Article Type: 001-Hot Stabs  
 Main Group: 1.01. Ø35 Hot Stab  
 Intermediate Group: 1.1.01. Stab  
 Sub Group: 1.1.1.04. Quad

NOTE: 3  
 INTERFACE INFORMATION:  
 Pressure Rating Bar: 690  
 Material: Intervention  
 Weight: 4,7 kg  
 Volume: 0,68 dm<sup>3</sup>  
 Surface Area: 1803 cm<sup>2</sup>  
 Hydraulic: 3/8" BSP  
 Mechanical: N/A  
 Electrical: N/A  
 Com. & Protocol: N/A

NOTE: 4  
 SPAREPARTS:  
 BA5286

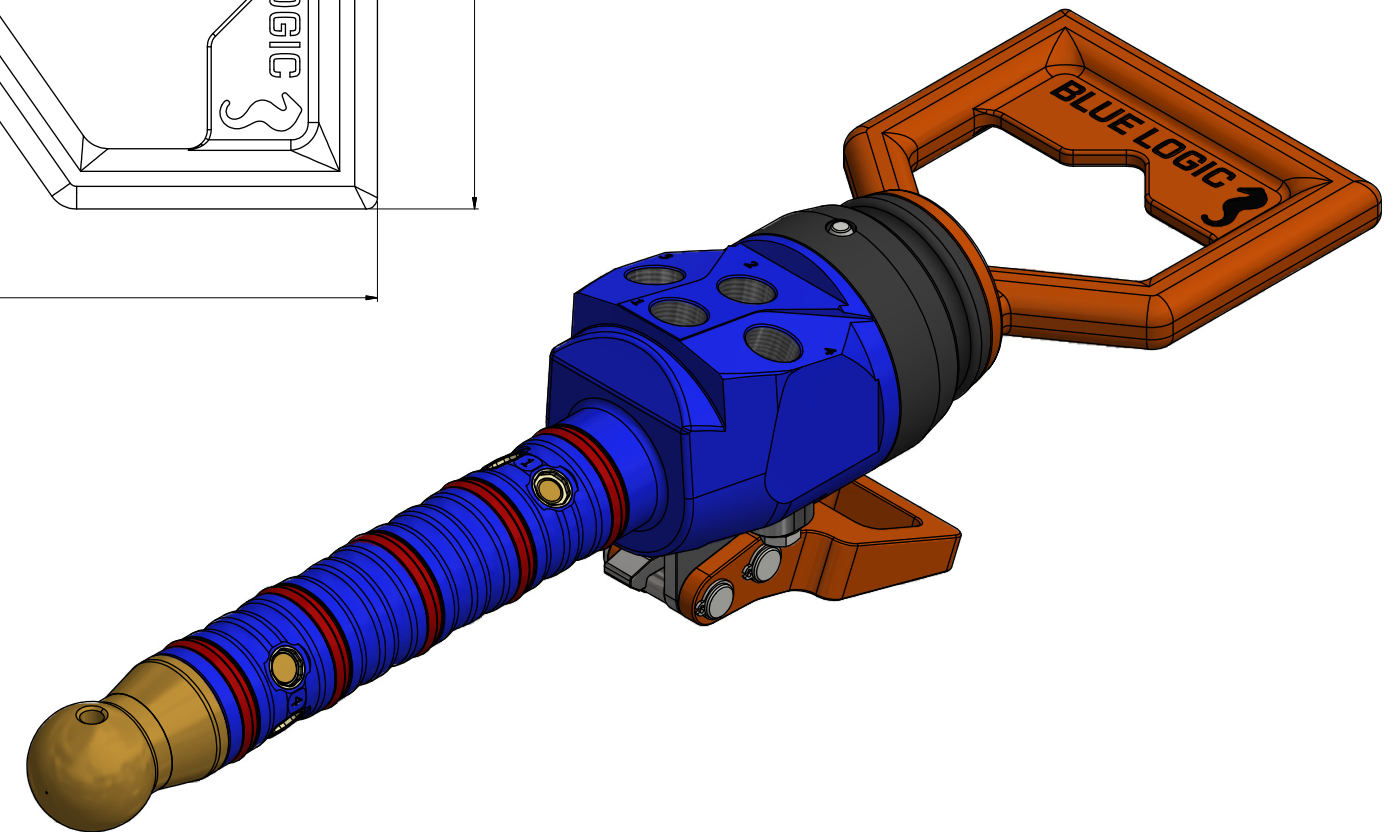
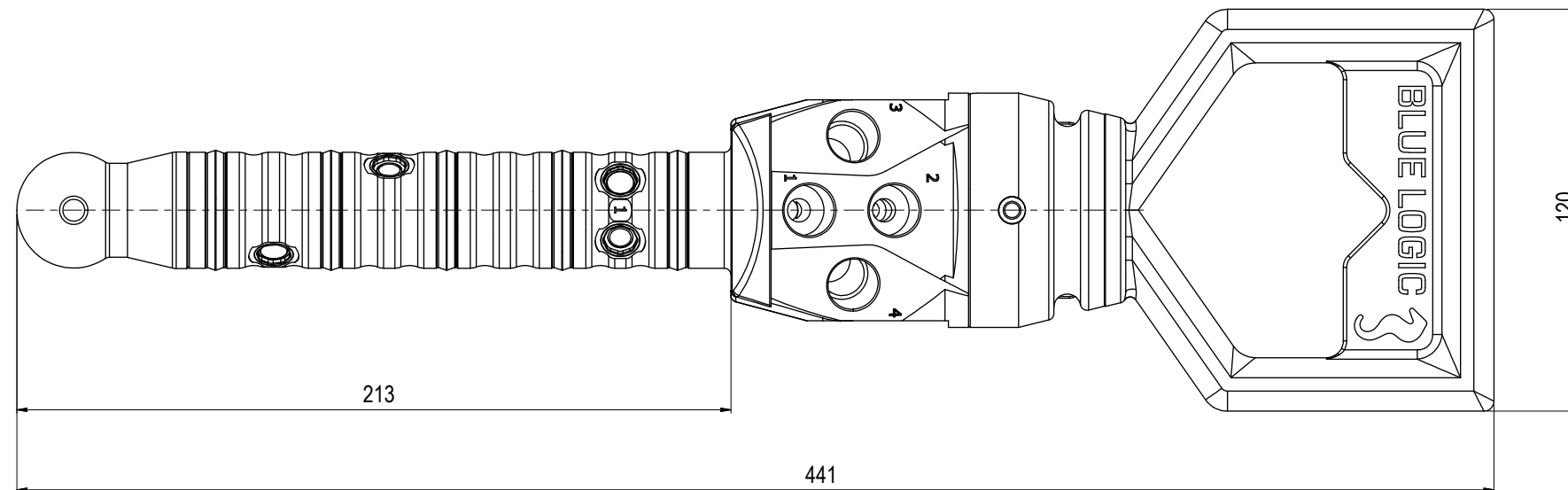
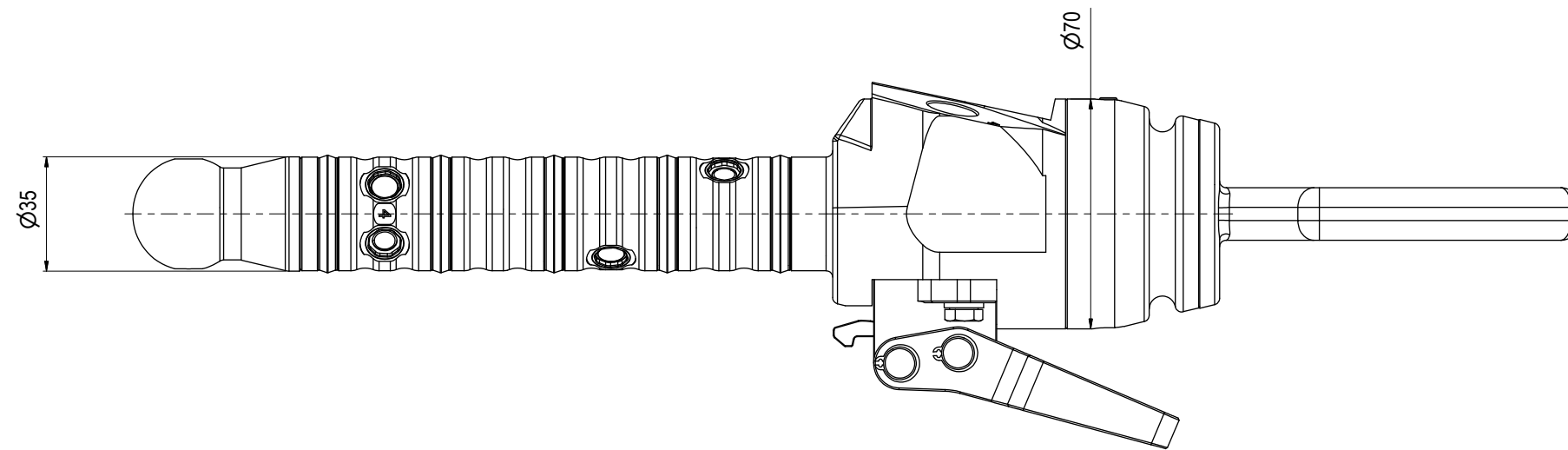

08	22.6.2022	9-IFU (Issued for Use)		WTJ	HNJ	WTJ
07	13.1.2022	9-IFU (Issued for Use)		WTJ	HNJ	WTJ
06	13.8.2020	9-IFU (Issued for Use)		WTJ	LGH	WTJ
05	17.3.2016	9-IFU (Issued for Use)		HNJ	WTJ	HNJ
Rev.	Date	Reason for issue	Revision change	Made	Chk'd	Appr.



Dwg Scale:  
 NTS  
 Dwg Proj:  
  
 Dwg Format:  
 A3

Drawing title:  
 Ø35 QP Stab 10k Interv wCV WL BSP 3/8" ID5,5mm

Drawing number:  
 BA1082

Rev.  
 08